

iT0750 Ice Cube Machine

Model: IDT0750A IYT0750A IDT0750W IYT0750W



iT0750 Ice Cube Machine



Indigo NXT Series iT0750 Ice Machine on a D570 Bin

Designed for operators who know that ice is critical to their business, the Indigo@NXT Series ice machine's preventative diagnostics continually monitor itself for reliable ice production. Improvements in cleanability and programmability make your ice machine easy to own and less expensive to operate.

- **easyTouch[®] Display**- New icon based touch screen takes the guess work out of owning and operating an ice machine.
- **Programmable Ice Production** - Now its super easy to program your ice machine to be off at certain times of the day to save money with fluctuating electrical rates. Also programmable by daily ice production volume.
- **Easy to Clean Foodzone** - Hinged front door swings out for easy access. Removable water-trough, distribution tube, curtain, and sensing probes for fast and efficient cleaning. Select components made with AlphaSan[®] antimicrobial.
- **Intelligent Diagnostics** - provide 24 hour preventative maintenance and diagnostic feedback for trouble free operation.
- **Acoustical Ice Sensing Probe** - Unique patented technology allows for reliable operation in challenging water conditions and environments.
- **DuraTech[™] Exterior** - provides superior corrosion resistant above stainless steel. Innovative clear-coat resists fingerprints and dirt making it easy to keep clean.
- **Available LuminIce II Growth Inhibitor**- Controls the growth of bacteria and yeast with the food zone keep the machine cleaner longer. A new indicator in the display keeps you abreast of the operational status.
- **Active Sense**: insures consistent ice harvest in all environmental conditions. This software and/or hardware solution works in conjunction with the acoustical ice sensing probe improving reliability and performance.

Ice Machine Electric

208-230/60/1 standard.
(230/50/1 also available)

Minimum circuit capacity: **Maximum fuse size:**

Air Cooled: 11.1
Water Cooled: 7.9

Air Cooled: 15
Water Cooled: 15

Specifications

BTU Per Hour:

12,800 (average)
13,700 (peak)

Refrigerant:

R410A CFC-free
Reduces Global Warming by 48%

Operating Limits:

- Ambient Temperature Range: 40° to 119° F (4.4 to 43.3 C)
Water Temperature Range: 40° to 90° F (4.4 to 32.2 C)
- Water Pressure Ice Maker
Water In:
Min. 20 psi (137.9 kPa)
Max. 80 psi (551.1 kPa)

Ice Shape



Half Dice
3/8" x 1 1/8" x 7/8"
(.95 x 2.86 x 2.22 cm)



Dice
7/8" x 7/8" x 7/8"
(2.22 x 2.22 x 2.22 cm)



COMPANY WITH
QUALITY SYSTEM
CERTIFIED BY DNV
= ISO 9001:2015 =



iT0750 on D-570 Storage Bin

- Ⓐ Electrical Entrance (2) Options
- Ⓑ 3/8" (0.95 cm) F.P.T. Water Condenser Inlet (water-cooled units)
- Ⓒ 1/2" (1.27 cm) F.P.T. Water Condenser Outlet (water-cooled units)
- Ⓓ 1/2" (1.27 cm) Auxillary Base Drain Socket
- Ⓔ 3/8" (0.95 cm) F.P.T. Ice Making Water Inlet
- Ⓕ 1/2" (1.27 cm) F.P.T. Ice Making Water Drain
- Ⓖ 3/4" (1.91 cm) Bin Drain

Installation Note
Minimum installation clearance:

Top/sides: 8" (20.32 cm); Back is 5" (12.7 cm)

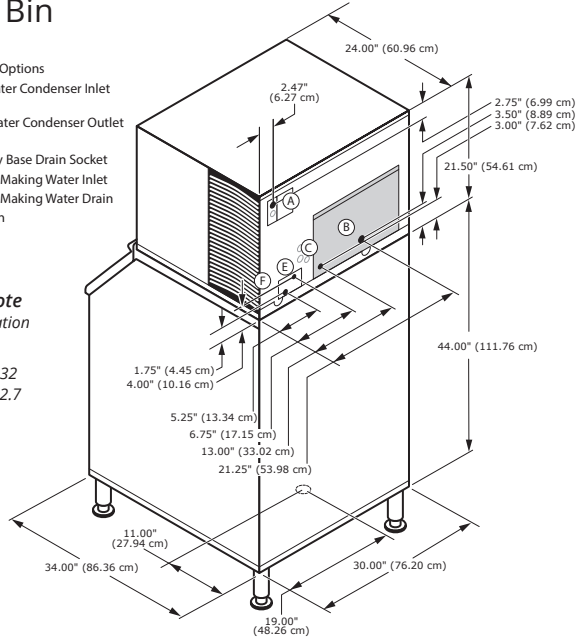

Space-Saving Designs



	iT0750 D-400	iT0750 D-570
Height	59.50" 151.13 cm	71.50" 181.61 cm
Width	30.00" 76.20 cm	30.00" 76.20 cm
Depth	34.00" 86.30 cm	34.00" 86.30 cm
Bin Storage	365 lbs. 165.7 kgs	543 lbs. 241.1 kgs

Height includes adjustable bin legs 6.00" to 8.00", (15.24 to 20.32 cm) set at 6.00" (15.24 cm). Bin capacity is based on 90% of the volume x 33 lbs/ft³ average density of ice

Specifications

	Model	Ice Shape	Ice Production 24 Hours		Power Usage kWh/100 lbs. @90°Air/70°F	Potable Water Usage/100 lbs. 45.4 kgs of Ice	ENERGY STAR®
			70°Air/ 50°F Water 21° Air/10°C Water	90°Air/ 70°F Water 32° Air/21°C Water			
AIR-COOLED	IDT0750A	dice	680 lbs.	540 lbs.	5.24 *	20.0 Gal.	★
			308 kgs	245 kgs		75.7 L	
AIR-COOLED	IYT0750A	half-dice	715 lbs.	575 lbs.	5.12 *	20.0 Gal.	★
			324 kgs	261 kgs		75.7 L	
WATER-COOLED	IDT0750W	dice	703 lbs.	600 lbs.	4.07	20.0 Gal.	
			319 kgs	272 kgs		75.7 L	
WATER-COOLED	IYT0750W	half-dice	740 lbs.	650 lbs.	3.79	20.0 Gal.	
			336 kgs	295 kgs		75.7 L	

* Water-cooled Condenser Water Usage / 100 lbs. /45.4 kgs Of Ice: 135 gal/511 L.
* Water-cooled models are excluded from ENERGY STAR qualification.

Accessories

LuminIce® II Growth Inhibitor
reduces yeast and bacteria growth for a cleaner ice machine.



External Scoop holder

Protect the ice scoop with the NSF approved versatile scoop holder.



Arctic Pure® Water Filters

Reduces sediment and chlorine odors for better tasting ice.



iAuCS®

schedules and performs routine ice machine cleaning automatically.

